MOLDING POWER INDUCTORS

1. Features

- High rated current
- Frequency up to 3MHz
- 125°C maximum total temperature operation
- Low core loss
- Ultra low buzz noise due to molding construction
- Halogen Free & ROHS compliant

2. Applications

- Laptops and PCs
- Switch and servers
- Base stations
- DC/DC converters
- Battery powered devices
- SSD modules



3. Product Identification

JMC XXXX --- XXX M
① ② ③ ④

- ① Series name
- ② Dimensions and shape (0412~1260)
- ③ Inductance Value
- ④ Inductance Tolerance (M= ± 20%)

4. Dimensions (unit:mm)

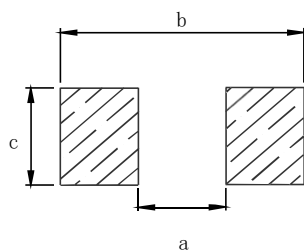
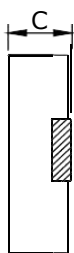
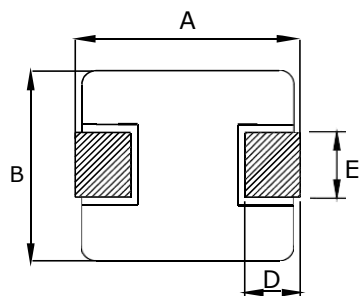

Recommend Land Pattern

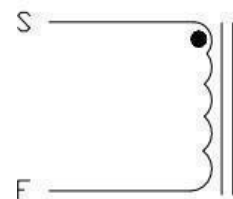

SCHEMATIC DRAWING

series	A	B	C	D	E	a typ	b typ	c typ
JMC0412	4.4±0.35	4.2±0.25	1.0±0.2	0.8±0.3	2.0±0.3	2.2	5.2	2.5
JMC0402	4.4±0.35	4.2±0.25	1.8±0.2	0.8±0.3	2.0±0.3	2.2	5.2	2.5
JMC0518	5.4±0.35	5.2±0.2	1.6±0.2	1.2±0.2	2.2±0.3	2.2	6	2.5
JMC0502	5.4±0.35	5.2±0.2	1.8±0.2	1.2±0.2	2.2±0.3	2.2	6	2.5
JMC0503	5.4±0.35	5.2±0.2	2.8±0.2	1.2±0.2	2.2±0.3	2.2	6	2.5
JMC0602	7.0±0.3	6.6±0.2	1.8±0.2	1.6±0.3	3.0±0.3	3.7	8.4	3.5
JMC0624	7.0±0.3	6.6±0.2	2.2±0.2	1.6±0.3	3.0±0.3	3.7	8.4	3.5
JMC0603	7.0±0.3	6.6±0.2	2.8±0.2	1.6±0.3	3.0±0.3	3.7	8.4	3.5
JMC0604	7.0±0.3	6.6±0.2	3.8±0.2	1.6±0.3	3.0±0.3	3.7	8.4	3.5
JMC0605	7.0±0.3	6.6±0.2	4.8±0.2	1.6±0.3	3.0±0.3	3.7	8.4	3.5
JMC1004	11.5MAX	10.0±0.3	3.8±0.2	2.0±0.5	3.0±0.5	5.4	13.6	4.1
JMC1204	13.45±0.35	12.8±0.5	4.0MAX	2.0±0.5	See Remarks	8.0	14.5	5.5
JMC1205	13.45±0.35	12.6±0.3	4.8±0.2	2.0±0.5	See Remarks	8.0	14.5	5.5
JMC1265	13.45±0.35	12.6±0.3	6.3±0.2	2.0±0.5	5.0±0.3	8.0	14.5	5.5

Remarks:

series	E	Dimensions
JMC1204	3.85±0.5	R22/R47
	5.0±0.3	R68/R82/1R0/1R5/2R2/3R3/4R7/6R8/100/150/220
JMC1205	3.85±0.5	R22/R36/R50/R68/R82/1R0/1R5/2R2
	5.0±0.3	3R3/4R7/6R8/100/150/220/330/470

5. Marking

The inductor is marked with a 3-digit code

Nominal Inductance	
Example	Nominal Value
1R0	1.0 μH
100	10 μH
101	100 μH

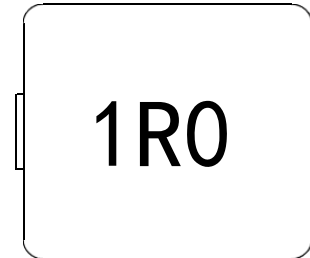

Note : Using Ink for marking

6. Structure and Components

Symbol	Components	Material
a	MARKING	Ink(black)
b	CORE	Alloy Sponge Powder
c	WIRE	Polyurethane copper wire
d	Terminal	Copper plated with Sn

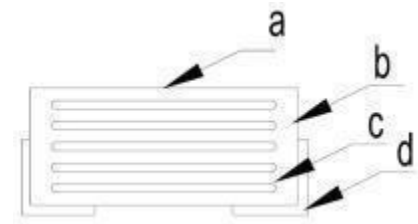

7. Electrical characteristics

•JMC0412TYPE:

Part No.	Inductance	DC Resistance	Saturation Current	Heating Rating Current
	L0 (μH)	DCR (mΩ)	Isat (A)	Irms (A)
	±20 %, 100 kHz, 1V	MAX.	TYP.	TYP.
JMC0412-R15M	0.15	9	15	7.5
JMC0412-R22M	0.22	11	11	7
JMC0412-R33M	0.33	19	8.4	6.5
JMC0412-R47M	0.47	21	6.8	6
JMC0412-R68M	0.68	36	6	4.7
JMC0412-1R0M	1.0	47	5.5	4.5
JMC0412-1R5M	1.5	75	4	3.25
JMC0412-2R2M	2.2	83.5	3	2.75
JMC0412-4R7M	4.7	195	2.2	1.8

•JMC0402TYPE:

Part No.	Inductance	DC Resistance	Saturation Current	Heating Rating Current
	L0 (μH)	DCR (mΩ)	Isat (A)	Irms (A)
	±20 %, 100 kHz, 1V	MAX.	TYP.	TYP.
JMC0402-R10M	0.1	4	22	13
JMC0402-R22M	0.22	6.6	12.5	9.5
JMC0402-R33M	0.33	11	12	10
JMC0402-R47M	0.47	14	9.5	7.5
JMC0402-R56M	0.56	16	9	7
JMC0402-R68M	0.68	18	8	7
JMC0402-1R0M	1.0	27	7	6
JMC0402-1R2M	1.2	27	6.5	6
JMC0402-1R5M	1.5	46	5.5	5
JMC0402-2R2M	2.2	58	5	4.5
JMC0402-3R3M	3.3	87	3.5	3.3
JMC0402-4R7M	4.7	105	3	2.8
JMC0402-6R8M	6.8	175	2.5	2.4
JMC0402-100M	10	282	2	1.6
JMC0402-220M	22	363	1.4	1.2

•JMC0518TYPE:

Part No.	Inductance	DC Resistance	Saturation Current	Heating Rating Current
	L0 (μH)	DCR (mΩ)	Isat (A)	Irms (A)
	±20 %, 100 kHz, 1V	MAX.	TYP.	TYP.
JMC0518-R47M	0.47	9	12.0	10.5
JMC0518-R56M	0.56	10	11	9.5
JMC0518-1R0M	1.0	17	9.0	8.0
JMC0518-1R5M	1.5	26	8	7.5
JMC0518-2R2M	2.2	35	6.0	5.0
JMC0518-3R3M	3.3	58	4.8	4.5
JMC0518-4R7M	4.7	85	4.0	3.5
JMC0518-6R8M	6.8	120	3.4	2.8
JMC0518-100M	10	155	2.5	2.5

•JMC0502TYPE:

Part No.	Inductance	DC Resistance	Saturation Current	Heating Rating Current
	L0 (μH)	DCR (mΩ)	Isat (A)	Irms (A)
	±20 %, 100 kHz, 1V	MAX.	TYP	TYP
JMC0502-R22M	0.22	4.5	19	15
JMC0502-R47M	0.47	9	16	10.5
JMC0502-R56M	0.56	10	15	9.5
JMC0502-1R0M	1.0	17	9.5	8.0
JMC0502-1R5M	1.5	30	8.5	5.5
JMC0502-2R2M	2.2	34	7	5
JMC0502-3R3M	3.3	58	5.5	4.5
JMC0502-4R7M	4.7	78	4.5	3.5
JMC0502-6R8M	6.8	120	3.5	2.8
JMC0502-8R2M	8.2	150	3.3	2.6
JMC0502-100M	10	175	3	2.5

•JMC0503 TYPE:

Part No.	Inductance	DC Resistance	Saturation Current	Heating Rating Current
	L0 (μH)	DCR (mΩ)	Isat (A)	Irms (A)
	±20 %, 100 kHz, 1V	MAX.	TYP.	TYP.
JMC0503-R10M	0.10	3.0	30	25
JMC0503-R20M	0.20	3.9	20	14
JMC0503-R33M	0.33	5.5	18	14
JMC0503-R47M	0.47	8.5	15	11
JMC0503-R68M	0.68	12	11.5	9.0
JMC0503-1R0M	1.0	14	10	8.5
JMC0503-1R2M	1.2	16	9.5	8.5
JMC0503-1R5M	1.5	25	9	8.2
JMC0503-2R2M	2.2	29	7.0	7.0
JMC0503-3R3M	3.3	38	6.0	5.5
JMC0503-4R7M	4.7	60	4.6	4.5
JMC0503-6R8M	6.8	90	3.6	3.5
JMC0503-100M	10	125	3.5	3.2

•JMC0602 TYPE

Part No.	Inductance	DC Resistance	Saturation Current	Heating Rating Current
	L0 (μH)	DCR (mΩ)	Isat (A)	Irms (A)
	±20 %, 100 kHz, 1V	MAX.	TYP.	TYP.
JMC0602-R10M	0.10	2.3	38	25
JMC0602-R22M	0.22	3.5	24	22
JMC0602-R47M	0.47	8.4	18	11.5
JMC0602-R68M	0.68	12	16.5	9.5
JMC0602-1R0M	1.0	16	12	8.5
JMC0602-1R5M	1.5	26	9.2	8
JMC0602-2R2M	2.2	35	8	7
JMC0602-3R3M	3.3	50	6	4.5
JMC0602-4R7M	4.7	62	5	4
JMC0602-6R8M	6.8	110	4.5	3
JMC0602-100M	10	155	4	2.3
JMC0602-220M	22	350	2.3	1.8

•JMC0624 TYPE

Part No.	Inductance	DC Resistance	Saturation Current	Heating Rating Current
	L0 (μH)	DCR (mΩ)	Isat (A)	Irms (A)
	±20 %, 100 kHz, 1V	MAX.	TYP.	TYP.
JMC0624-R22M	0.22	3	30	21
JMC0624-R33M	0.33	4.1	24.5	18
JMC0624-R47M	0.47	5.1	20	15
JMC0624-R56M	0.56	6.5	17	13
JMC0624-R68M	0.68	7	16	12
JMC0624-1R0M	1.0	13.5	15	9
JMC0624-1R5M	1.5	20	13.5	8.2
JMC0624-2R2M	2.2	28	10	7
JMC0624-3R3M	3.3	39	8	5.5
JMC0624-4R7M	4.7	50	6.5	5
JMC0624-6R8M	6.8	70	6	4
JMC0624-100M	10	101	4	3.1
JMC0624-150M	15	160	3.3	2.5
JMC0624-220M	22	230	2.5	2

•JMC0603 TYPE

Part No.	Inductance	DC Resistance	Saturation Current	Heating Rating Current
	L0 (μH)	DCR (mΩ)	Isat (A)	Irms (A)
	±20 %, 100 kHz, 1V	MAX.	TYP.	TYP.
JMC0603-R22M	0.22	3	34	24
JMC0603-R33M	0.33	3.5	25	21
JMC0603-R47M	0.47	4.1	20	18
JMC0603-R56M	0.56	4.5	18	16.5
JMC0603-R68M	0.68	5.3	17	16
JMC0603-R82M	0.82	6.0	16	14
JMC0603-1R0M	1.0	7.4	15	12
JMC0603-1R5M	1.5	12.1	12	12
JMC0603-2R2M	2.2	15	10	9.5
JMC0603-3R3M	3.3	22	9.5	8.5
JMC0603-4R7M	4.7	33	9	6
JMC0603-5R6M	5.6	42	6.5	5.5
JMC0603-6R8M	6.8	48	6	5
JMC0603-8R2M	8.2	60	5.5	5
JMC0603-100M	10	68	5.5	4.5
JMC0603-150M	15	113	4.0	3
JMC0603-220M	22	170	3	2.5
JMC0603-330M	33	270	2.5	2
JMC0603-470M	47	385	2	1.5

•JMC0604 TYPE

Part No.	Inductance	DC Resistance	Saturation Current	Heating Rating Current
	L0 (μH)	DCR (mΩ)	Isat (A)	Irms (A)
	±20 %, 100 kHz, 1V	MAX.	TYP.	TYP.
JMC0604-2R2M	2.2	14	11.0	9
JMC0604-4R7M	4.7	30	9.0	7.0
JMC0604-150M	15	110	4.5	3.5

•JMC0605 TYPE:

Part No.	Inductance	DC Resistance	Saturation Current	Heating Rating Current
	L0 (μH)	DCR (mΩ)	Isat (A)	Irms (A)
	±20 %, 100 kHz, 1V	MAX.	TYP.	TYP.
JMC0605-R47M	0.47	3.9	21.0	20
JMC0605-R68M	0.68	4.5	18.0	16.5
JMC0605-1R0M	1.0	6.6	16.0	12
JMC0605-1R5M	1.5	10	13.0	9.5
JMC0605-2R2M	2.2	12.5	11.0	9
JMC0605-3R3M	3.3	22.0	10.0	8.5
JMC0605-4R7M	4.7	29	8	6
JMC0605-6R8M	6.8	41	6.3	5.8
JMC0605-8R2M	8.2	48	5.5	5.5
JMC0605-100M	10	60	5.3	4.5
JMC0605-150M	15	90	4.0	3.1
JMC0605-220M	22	140	3.5	2.6
JMC0605-330M	33	190	3.0	2.3
JMC0605-470M	47	230	2.6	2.0
JMC0605-560M	56	296	2.1	1.6

•JMC1004 TYPE

Part No.	Inductance	DC Resistance	Saturation Current	Heating Rating Current
	L0 (μH)	DCR (mΩ)	Isat (A)	Irms (A)
	±20 %, 100 kHz, 1V	MAX.	TYP.	TYP.
JMC1004-R15M	0.15	0.65	75	45
JMC1004-R22M	0.22	1	60	35
JMC1004-R30M	0.3	1.1	45	35
JMC1004-R36M	0.36	1.2	45	30
JMC1004-R47M	0.47	1.7	40	30
JMC1004-R56M	0.56	1.8	33	25
JMC1004-R68M	0.68	2.4	30	23
JMC1004-R80M	0.8	2.7	29	23
JMC1004-1R0M	1.0	3.3	28	19
JMC1004-1R5M	1.5	4.2	24	16
JMC1004-2R2M	2.2	7	16.5	12
JMC1004-3R3M	3.3	11.8	16	11
JMC1004-4R7M	4.7	20	13	9
JMC1004-6R8M	6.8	25	12	8.5
JMC1004-8R2M	8.2	27	9	8
JMC1004-100M	10	30	8.5	7.8
JMC1004-150M	15	45	7	6.5
JMC1004-220M	22	66	5.5	5
JMC1004-330M	33	92	4.8	4.4
JMC1004-470M	47	155	3.5	3.3
JMC1004-680M	68	195	3	2.5

•JMC1204 TYPE

Part No.	Inductance	DC Resistance	Saturation Current	Heating Rating Current
	L0 (μH)	DCR (mΩ)	Isat (A)	Irms (A)
	±20 %, 100 kHz, 1V	MAX.	TYP.	TYP.
JMC1204-R22M	0.22	0.9	50.0	42.0
JMC1204-R47M	0.47	2.0	48.0	33.0
JMC1204-R68M	0.68	3.5	47.0	28.0
JMC1204-R82M	0.82	4.5	40.0	28.0
JMC1204-1R0M	1.0	7.5	35.0	24.0
JMC1204-1R5M	1.5	9.5	30.5	20.0
JMC1204-2R2M	2.2	11.5	26.0	18.0
JMC1204-3R3M	3.3	13.0	21.0	15.0
JMC1204-4R7M	4.7	14.5	18.0	13.0
JMC1204-6R8M	6.8	20.0	14.0	9.0
JMC1204-100M	10.0	25.0	10.0	8.0
JMC1204-150M	15.0	39.0	7.5	6.5
JMC1204-220M	22.0	51.0	6.0	4.5

•JMC1205 TYPE

Part No.	Inductance	DC Resistance	Saturation Current	Heating Rating Current
	L0 (μH)	DCR (mΩ)	Isat (A)	Irms (A)
	±20 %, 100 kHz, 1V	MAX.	TYP.	TYP.
JMC1205-R22M	0.22	0.7	75	50
JMC1205-R36M	0.36	0.85	50	42
JMC1205-R50M	0.50	1.15	48	38
JMC1205-R68M	0.68	1.55	46	33
JMC1205-R82M	0.82	1.67	39	30
JMC1205-1R0M	1.0	2.2	35	26
JMC1205-1R5M	1.5	3.2	33	23
JMC1205-2R2M	2.2	5.0	24	15
JMC1205-3R3M	3.3	7	22	14
JMC1205-4R7M	4.7	9	20	13
JMC1205-6R8M	6.8	18	16	12
JMC1205-100M	10	22	12	9
JMC1205-150M	15	30	10	8
JMC1205-220M	22	58	6.5	4.5
JMC1205-330M	33	84	6.0	3.5
JMC1205-470M	47	130	5.0	3.0

•JMC1265 TYPE

Part No.	Inductance	DC Resistance	Saturation Current	Heating Rating Current
	L0 (μH)	DCR (mΩ)	Isat (A)	Irms (A)
	±20 %, 100 kHz, 1V	MAX.	TYP.	TYP.
JMC1265-4R7M	4.7	9.0	24.0	15.0
JMC1265-5R6M	5.6	11.0	22.5	13.0
JMC1265-6R8M	6.8	13.5	19.0	12.0
JMC1265-8R2M	8.2	16.0	13.5	11.0
JMC1265-100M	10.0	20.7	12.5	10.0
JMC1265-120M	12.0	23.0	10	9.0
JMC1265-150M	15.0	29.0	9.0	8.5
JMC1265-180M	18.0	35.0	8.0	7.5
JMC1265-220M	22.0	39.5	7.5	7.0
JMC1265-270M	27.0	56.0	6.5	6.0
JMC1265-330M	33.0	75.0	6.0	5.5
JMC1265-470M	47.0	90.0	5.5	5.0
JMC1265-680M	68.0	140.0	4.5	4.0
JMC1265-101M	100.0	200.0	3.5	3.0
JMC1265-121M	120.0	235.0	3.2	2.0
JMC1265-151M	150.0	350.0	2.7	1.5

• Notes

1. All test data is referenced to 25 °C ambient
2. Operating temperature range - 55 °C to + 125 °C
3. Irms (A):DC current (A) that will cause an approximate ΔT of 40 °C(reference ambient temperature is25°C)
4. Isat(A):DC current (A) that will cause L0 to drop approximately 30 %
5. The part temperature (ambient + temp rise) should not exceed 125 °C under worst case operating conditions.
Circuit design, component placement, PWB trace size and thickness, airflow and other cooling provisions all affect the part temperature. Part temperature should be verified in the end application.
6. Absolute maximum voltage 30VDC

8. Reliability Test

Item	Specification and Requirement	Test Method								
Solderability	<ol style="list-style-type: none"> No case deformation or change in appearance New solder coverage More than 90% 	<ol style="list-style-type: none"> Preheat: $155^{\circ}\text{C} \pm 5^{\circ}\text{C}$, $60\text{S} \pm 2\text{S}$ Tin: lead-free. Temperature: $245^{\circ}\text{C} \pm 5^{\circ}\text{C}$, flux $3.0\text{S} \pm 0.5\text{S}$. 								
Mechanical shock	<ol style="list-style-type: none"> No case deformation or change in appearance $\Delta L/L_0 \leq \pm 10\%$ 	<ol style="list-style-type: none"> Acceleration: 100G Pulse time: 6ms 3 times in each positive and negative direction of 3 mutual perpendicular directions 								
Mechanical vibration	<ol style="list-style-type: none"> No case deformation or change in appearance $\Delta L/L_0 \leq \pm 10\%$ 	<ol style="list-style-type: none"> The test samples shall be soldered to the board. Then it shall be submitted to below test conditions. <table border="1" data-bbox="874 936 1469 1070"> <tr> <td>Fre. Range</td> <td>10~55Hz</td> </tr> <tr> <td>Total Amplitude</td> <td>1.5mm</td> </tr> <tr> <td>Sweeping Method</td> <td>10Hz to 55Hz to 10Hz</td> </tr> <tr> <td>Time</td> <td>For 2 hours on each X,Y,Z axis.</td> </tr> </table> Recovery: At least 2 hours of recovery under the standard condition after the test, followed by the measurement within 24 ± 2 hours. 	Fre. Range	10~55Hz	Total Amplitude	1.5mm	Sweeping Method	10Hz to 55Hz to 10Hz	Time	For 2 hours on each X,Y,Z axis.
Fre. Range	10~55Hz									
Total Amplitude	1.5mm									
Sweeping Method	10Hz to 55Hz to 10Hz									
Time	For 2 hours on each X,Y,Z axis.									
Thermal Shock	<p>Inductance change: Within $\pm 10\%$ Without distinct damage in appearance</p>	<ol style="list-style-type: none"> First -55°C for 30 minutes, last 125°C for 30 minutes as 1 cycle. Go through 1000 cycles. Max transfer time is 2 minutes. Measured at room temperature after placing for 24 ± 2 hours 								
Humidity Resistance	<p>Inductance change: Within $\pm 10\%$ Without distinct damage in appearance</p>	<ol style="list-style-type: none"> Reflow 2 times, 85°C, 85%RH, 1000 hours Measured at room temperature after placing for 24 ± 2 hours 								
Low temperature storage	<p>Inductance change: Within $\pm 10\%$ Without distinct damage in appearance</p>	<ol style="list-style-type: none"> Temperature: $-55 \pm 2^{\circ}\text{C}$ Time: 1000 hours Measured at room temperature after placing for 24 ± 2 hours 								

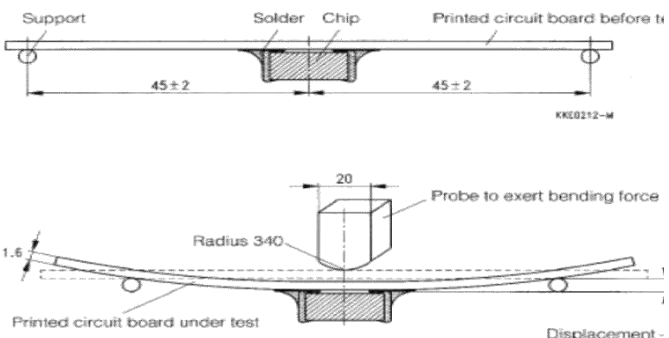
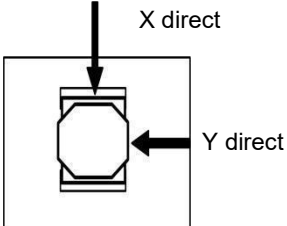
<p>High temperature storage</p>	<p>Inductance change: Within $\pm 10\%$ Without distinct damage in appearance</p>	<ol style="list-style-type: none"> 1. Temperature: $+125 \pm 2^\circ\text{C}$ 2. Time: 1000 hours 3. Measured at room temperature after placing for 24 ± 2 hours
<p>Board Flex</p>	<p>Inductance change: Within $\pm 10\%$ Without distinct damage in appearance</p>	<ol style="list-style-type: none"> 1. Run through IR reflow for 2 times; 2. Place the 100mm X 40mm board into a fixture similar to the one shown in below Figure with the component facing down 3. The apparatus shall consist of mechanical means to apply a force which will bend the board (D) x = 2 mm minimum. 4. The duration of the applied forces shall be 60 ± 5 sec. The force is to be applied only once to the board. 
<p>Terminal Strength</p>	<p>No removal or split of the termination or other defects shall occur.</p>	<ol style="list-style-type: none"> 1. The test samples shall be soldered to the board 2. Push the product vertically from the side of the sample using the thrust tester. 3. Automotive electronics: 17.7N, $60S \pm 1s$, X , Y direct. 

Recommended Soldering Technologies

(1) Re-flowing Profile

Preheat condition: 150 ~200°C/60~180sec.

Allowed time above 217°C: 80~120sec.

Max temp: 260°C

Max time at max temp: 10 sec.

Solder paste: Sn/3.0Ag/0.5Cu

Allowed Reflow time: 2x max

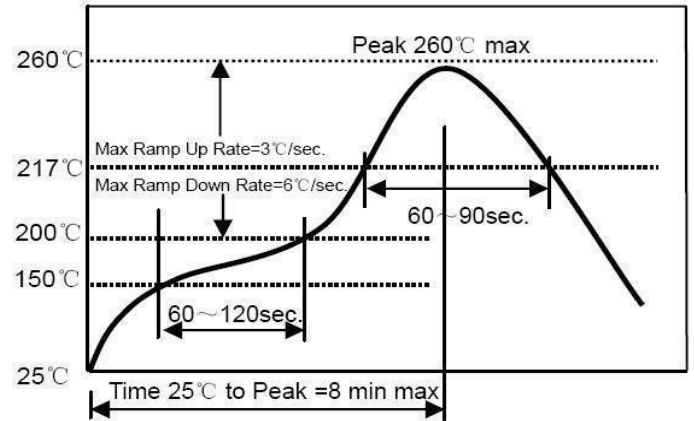

(2) Iron Soldering Profile

Iron soldering power: Max. 30W

Pre-heating: 150°C/60sec.

Soldering time: 3sec.Max.

Solder paste: Sn/3.0Ag/0.5Cu

Max.1 times for iron soldering

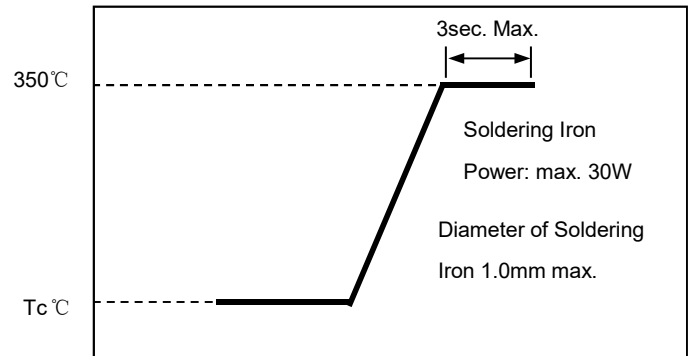

9. Packaging, Storage and Transportation

- Tape Carrier Packaging:

Type	Standard Quantity (pcs/reel)	Type	Standard Quantity (pcs/reel)
JMC0412	3000	JMC0604	1000
JMC0402	3000	JMC0605	1000
JMC0518	2500	JMC1004	1000
JMC0502	2500	JMC1045	800
JMC0503	1500	JMC1204	500
JMC0602	1500	JMC1205	500
JMC0624	1500	JMC1265	400
JMC0603	1000		

- Taping Drawings (UNIT:mm)

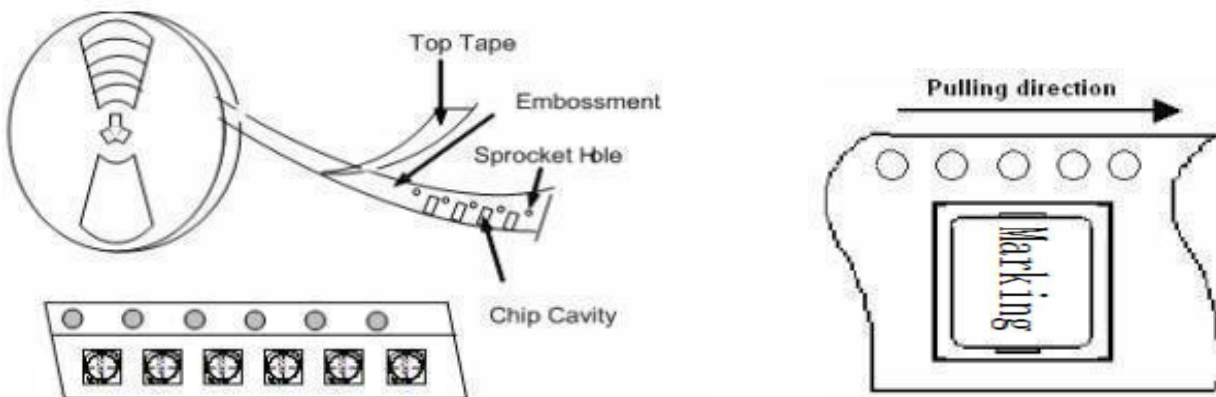

- Reel and Taping Dimensions (UNIT:mm)

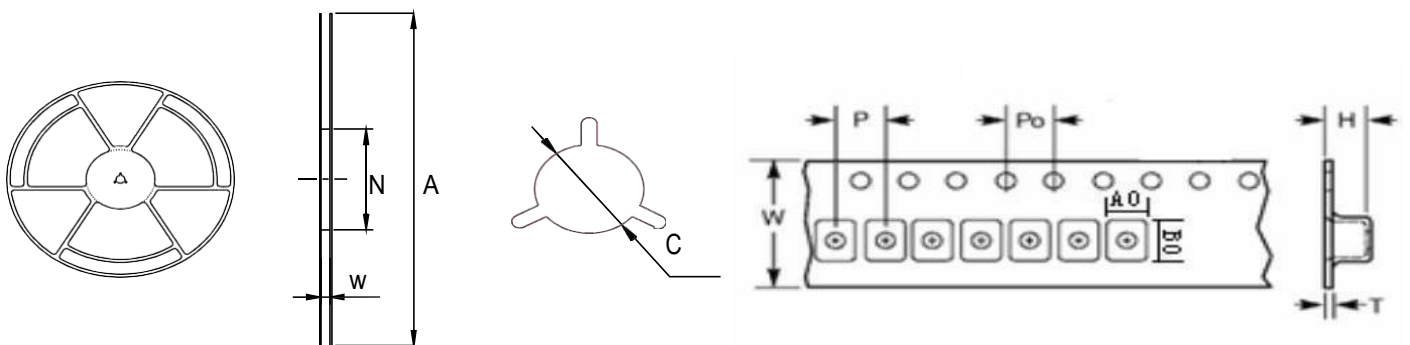

Type	Reel Dimensions (mm)				Tape Dimensions (mm)							
	A	N	W	C	W	P	P0	A0	B0	H	T	
JMC0412	330 +2/-0	100 +2/-0	12.4 +2/-0	13.2 ±0.2	12±0.3	8±0.1	4±0.1	4.4±0.1	4.9±0.1	1.5±0.05	0.3±0.05	
JMC0402	330 +2/-0	100 +2/-0	12.4 +2/-0	13.2 ±0.2	12±0.3	8±0.1	4±0.1	4.4±0.1	4.9±0.1	2.3±0.05	0.35±0.05	
JMC0518	330 +2/-0	100 +2/-0	12.4 +2/-0	13.2 ±0.2	12±0.3	8±0.1	4±0.1	5.4±0.1	5.9±0.1	2.1±0.05	0.35±0.05	
JMC0502	330 +2/-0	100 +2/-0	12.4 +2/-0	13.2 ±0.2	12±0.3	8±0.1	4±0.1	5.5±0.1	5.85±0.1	2.2±0.1	0.35±0.05	
JMC0503	330 +2/-0	100 +2/-0	12.4 +2/-0	13.2 ±0.2	12±0.3	8±0.1	4±0.1	5.4±0.1	5.9±0.1	3.3±0.05	0.35±0.05	
JMC0602	330 +2/-0	100 +2/-0	16.4 +2/-0	13.2 ±0.2	16±0.3	12±0.1	4±0.1	6.9±0.1	7.5±0.1	2.1±0.05	0.35±0.05	
JMC0624	330 +2/-0	100 +2/-0	16.4 +2/-0	13.2 ±0.2	16±0.3	12±0.1	4±0.1	6.9±0.1	7.5±0.1	2.7±0.05	0.35±0.05	
JMC0603	330 +2/-0	100 +2/-0	16.4 +2/-0	13.2 ±0.2	16±0.3	12±0.1	4±0.1	6.9±0.1	7.5±0.1	3.3±0.05	0.35±0.05	
JMC0604	330 +2/-0	100 +2/-0	16.4 +2/-0	13.2 ±0.2	16±0.3	12±0.1	4±0.1	6.9±0.1	7.5±0.1	4.2±0.1	0.35±0.05	
JMC0605	330 +2/-0	100 +2/-0	16.4 +2/-0	13.2 ±0.2	16±0.3	12±0.1	4±0.1	6.9±0.1	7.5±0.1	5.2±0.1	0.4±0.05	
JMC1004	330 +2/-0	100 +2/-0	24.4 +2/-0	13.2 ±0.2	24±0.3	16±0.1	4±0.1	10.4±0.1	11.5±0.1	4.3±0.1	0.35±0.05	
JMC1045	330 +2/-0	100 +2/-0	24.4 +2/-0	13.2 ±0.2	24±0.3	16±0.1	4±0.1	10.4±0.1	11.5±0.1	4.8±0.1	0.35±0.05	
JMC1204	330 +2/-0	100 +2/-0	24.4 +2/-0	13.2 ±0.2	24±0.3	16±0.1	4±0.1	13.4±0.1	14.4±0.1	4.3±0.1	0.5±0.05	
JMC1205	330 +2/-0	100 +2/-0	24.4 +2/-0	13.2 ±0.2	24±0.3	16±0.1	4±0.1	13.2±0.1	14.4±0.1	5.3±0.1	0.5±0.05	
JMC1265	330 +2/-0	100 +2/-0	24.4 +2/-0	13.2 ±0.2	24±0.3	16±0.1	4±0.1	13.2±0.1	14.4±0.1	6.3±0.1	0.5±0.05	

-
- Peel force of top cover tape
The peel speed shall be about 300mm/minute
The peel force of top cover tape shall be between 0.1 to 1.3 N

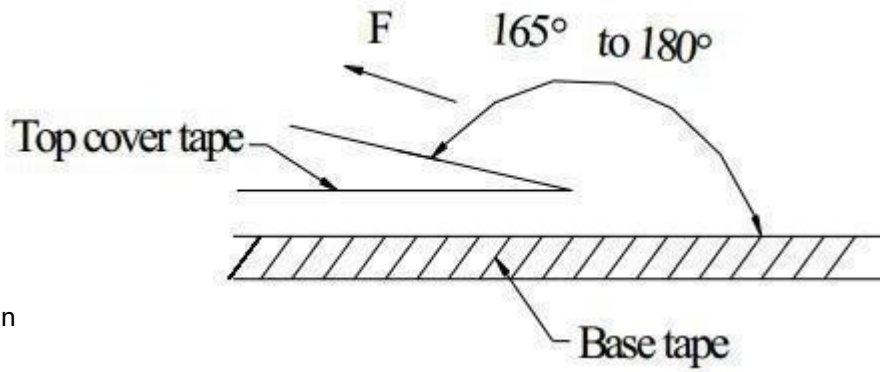

- Label makin

Label on the reel

- Customer's part Number
- Lot Number
- Quantity
- date code

Shipping Label

- Customer's part Number
- Manufacturer's part Number
- Quantity
- date code

